



Health Care Storage & Handling Equipment





Wire Shelving Systems



Unique design offers high volume, easy access storage in a variety of finishes to suit your needs. Open wire truss reinforced shelves feature front to back welded surface ribs for added strength. Increases light penetration, free air circulation and merchandise visibility. Minimize moisture and dust accumulation. Easily adjustable and expandable to change with your needs. Chrome finish.

WIRE SHELF

| Size W" x L" | Model No. |
|-----------------|-----------|
| 14 x 24 | S1424C |
| 14 x 30 | S1430C |
| 14 x 36 | S1436C |
| 14 x 42 | S1442C |
| 14 x 48 | S1448C |
| 14 x 54 | S1454C |
| 14 x 60 | S1460C |
| 14 x 72 | S1472C |
| 18 x 24 | S1824C |
| 18 x 30 | S1830C |
| 18 x 36 | S1836C |
| 18 x 42 | S1842C |
| 18 x 48 | S1848C |
| 18 x 54 | S1854C |
| 18 x 60 | S1860C |
| 18 x 72 | S1872C |
| 21 x 24 | S2124C |
| 21 x 30 | S2130C |
| 21 x 36 | S2136C |
| 21 x 42 | S2142C |
| 21 x 48 | S2148C |
| 21 x 54 | S2154C |
| 21 x 60 | S2160C |
| 21 x 72 | S2172C |
| 24 x 24 | S2424C |
| 24 x 30 | S2430C |
| 24 x 36 | S2436C |
| 24 x 42 | S2442C |
| 24 x 48 | S2448C |
| 24 x 54 | S2454C |
| 24 x 60 | S2460C |
| 24 x 72 | S2472C |

EXTRA WIDE SHELF

| Size W" x L" | Model No. |
|-----------------|-----------|
| 30 x 36 | S3036C |
| 30 x 48 | S3048C |
| 30 x 60 | S3060C |
| 30 x 72 | S3072C |
| 36 x 36 | S3636C |
| 36 x 48 | S3648C |
| 36 x 60 | S3660C |
| 36 x 72 | S3672C |

Includes Shelf Clips

POSTS

| Size" | Model No. |
|-------|-----------|
| 6 | P6C |
| 14 | P14C |
| 34 | P34C |
| 54 | P54C |
| 63 | P63C |
| 66 | P66C |
| 74 | P74C |
| 86 | P86C |
| 96 | P96C |

Includes Post Levelers



EASY TO ASSEMBLE

- No tools required
- Posts are numbered
- Shelves adjust on 1" increments
- Shelf clips snap on post, allowing shelf collar to slide over for a secure fit

Includes Shelf Clips

Starter unit consists of 4 posts, 4 shelves and plastic shelf clips in the height and shelf size indicated.

Add-on unit consists of 2 posts, 4 shelves, plastic shelf clips and two S-hooks for each shelf.



ADD-ON UNIT

Shelves packed four per carton, except 54", 60", 72" long and all extra wide shelves, which are packed two per carton. Posts are packed four per carton.

| Size W" x L" | 4 SHELVES - 63"H | | 4 SHELVES - 74"H | | 4 SHELVES - 86"H | |
|-----------------|----------------------|---------------------|----------------------|---------------------|----------------------|---------------------|
| | STARTER Model No. | ADD-ON Model No. | STARTER Model No. | ADD-ON Model No. | STARTER Model No. | ADD-ON Model No. |
| 18 x 24 | 18246C | A18246C | 18247C | A18247C | 18248C | A18248C |
| 18 x 30 | 18306C | A18306C | 18307C | A18307C | 18308C | A18308C |
| 18 x 36 | 18366C | A18366C | 18367C | A18367C | 18368C | A18368C |
| 18 x 42 | 18426C | A18426C | 18427C | A18427C | 18428C | A18428C |
| 18 x 48 | 18486C | A18486C | 18487C | A18487C | 18488C | A18488C |
| 18 x 54 | 18546C | A18546C | 18547C | A18547C | 18548C | A18548C |
| 18 x 60 | 18606C | A18606C | 18607C | A18607C | 18608C | A18608C |
| 18 x 72 | 18726C | A18726C | 18727C | A18727C | 18728C | A18728C |
| 24 x 24 | 24246C | A24246C | 24247C | A24247C | 24248C | A24248C |
| 24 x 30 | 24306C | A24306C | 24307C | A24307C | 24308C | A24308C |
| 24 x 36 | 24366C | A24366C | 24367C | A24367C | 24368C | A24368C |
| 24 x 42 | 24426C | A24426C | 24427C | A24427C | 24428C | A24428C |
| 24 x 48 | 24486C | A24486C | 24487C | A24487C | 24488C | A24488C |
| 24 x 54 | 24546C | A24546C | 24547C | A24547C | 24548C | A24548C |
| 24 x 60 | 24606C | A24606C | 24607C | A24607C | 24608C | A24608C |
| 24 x 72 | 24726C | A24726C | 24727C | A24727C | 24728C | A24728C |

Solid Shelf Units & Accessories



Choice of Galvanized or Stainless Steel

Solid shelf shelving units accept a variety of accessories to adapt to your changing needs. Dual layer construction provides maximum rigidity and strength. Open styling allows shelves to be reached from all sides for the ultimate in space efficiency. Fast, easy assembly, no tools required. Shelves with plastic shelf clips easily lock into place on posts and are adjustable on 1" increments. Leveling feet compensate for uneven floor surfaces. Finished in attractive, temperature and moisture resistant Galvanized or Stainless Steel. 400-600 lb. capacity per shelf.



Starter unit consists of 4 posts, 4 shelves and plastic shelf clips. Add-on unit (not shown) consists of 2 posts, 4 shelves, plastic shelf clips and two joining clamps per shelf.



STARTER UNIT



SHELVES

Durable 18 gauge steel shelf adds versatility to open wire units and allows for display style storage of small equipment and instruments that might fall through wire shelves.

| W" x L" | 63" High Unit | | 74" High Unit | | 86" High Unit | |
|---------|-------------------|------------------|-------------------|------------------|-------------------|------------------|
| | Starter Model No. | Add-On Model No. | Starter Model No. | Add-On Model No. | Starter Model No. | Add-On Model No. |
| 18 x 36 | 18366SZ | A18366SZ | 18367SZ | A18367SZ | 18368SZ | A18368SZ |
| 18 x 48 | 18486SZ | A18486SZ | 18487SZ | A18487SZ | 18488SZ | A18488SZ |
| 18 x 60 | 18606SZ | A18606SZ | 18607SZ | A18607SZ | 18608SZ | A18608SZ |
| 18 x 72 | 18726SZ | A18726SZ | 18727SZ | A18727SZ | 18728SZ | A18728SZ |
| 24 x 36 | 24366SZ | A24366SZ | 24367SZ | A24367SZ | 24368SZ | A24368SZ |
| 24 x 48 | 24486SZ | A24486SZ | 24487SZ | A24487SZ | 24488SZ | A24488SZ |
| 24 x 60 | 24606SZ | A24606SZ | 24607SZ | A24607SZ | 24608SZ | A24608SZ |
| 24 x 72 | 24726SZ | A24726SZ | 24727SZ | A24727SZ | 24728SZ | A24728SZ |

| W" x L" | Galvanized | | Stainless | |
|---------|-------------------|------------------|-------------------|------------------|
| | Starter Model No. | Add-On Model No. | Starter Model No. | Add-On Model No. |
| 18 x 36 | 18366SS | A18366SS | 18367SS | A18367SS |
| 18 x 48 | 18486SS | A18486SS | 18487SS | A18487SS |
| 18 x 60 | 18606SS | A18606SS | 18607SS | A18607SS |
| 18 x 72 | 18726SS | A18726SS | 18727SS | A18727SS |
| 24 x 36 | 24366SS | A24366SS | 24367SS | A24367SS |
| 24 x 48 | 24486SS | A24486SS | 24487SS | A24487SS |

| W" x L" | Galvanized | | Stainless | |
|---------|------------|-----------|-----------|-----------|
| | Model No. | Model No. | Model No. | Model No. |
| 18 x 36 | S1836SZ | S1836SS | 24 x 48 | S2448SZ |
| 18 x 48 | S1848SZ | --- | 24 x 60 | S2460SZ |
| 18 x 60 | S1860SZ | --- | 24 x 72 | S2472SZ |
| 18 x 72 | S1872SZ | --- | --- | --- |
| 24 x 36 | S2436SZ | S2436SS | --- | --- |

RODS & CLIPS JOINING CLAMP



Enclose the sides and/or back of a solid shelving unit with easily installed rods. Rod hooks over outer edge of shelf and attaches to shelf with a spring clip. One spring clip is required for every shelf to rod connection. Each rod includes four spring clips. Order additional clips for units with more than four shelves.

| Size" | Model No. |
|------------|-----------|
| 52 | SR54C |
| 60 | SR63C |
| 72 | SR74C |
| 84 | SR86C |
| Extra Clip | SRT |



For add-on units. Use two per shelf. Model No. **SJC**

SHELF DIVIDERS



Increase shelf versatility with 8" high dividers that allow you to compartmentalize and keep contents in order. Easily attaches to solid shelf.

| Size" | Model No. |
|-------|-----------|
| 18 | SD18C |
| 24 | SD24C |

SHELF LEDGES

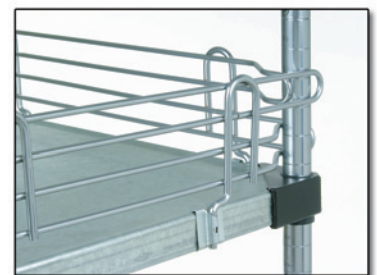

NOTE: All accessories are finished in a bright chrome.

Keep items on shelves during transport with 4" ledges. Allows you to increase items on shelf. Includes spring clips.

| Size" | Model No. |
|-------|-----------|
| 18 | SL18C |
| 24 | SL24C |
| 36 | SL36C |
| 48 | SL48C |
| 60 | SL60C |
| 72 | SL72C |



Adjustable Shelving



E-Z ADJUSTER WIRE SHELVING

Unique E-Z Adjust suspension hooks allow middle shelves to be adjusted, added or removed in seconds without disassembling entire unit. Simply lift shelf off post hooks and reposition to desired height. No tools. Features all the benefits of open wire shelving, minimizes dust accumulation, maximizes visibility, light and sprinkler penetration, and air circulation. Unit includes four posts, two standard shelves for stability at the top and bottom, and two Quick Adjust 400 lb. capacity shelves. All shelves adjust on 1" increments. Available in Chrome.

| W" x L" | CHROME | | |
|---------|-----------------------|-----------------------|-----------------------|
| | 63" HIGH Model No. | 74" HIGH Model No. | 86" HIGH Model No. |
| 18 x 36 | 18366AC | 18367AC | 18368AC |
| 18 x 48 | 18486AC | 18487AC | 18488AC |
| 18 x 60 | 18606AC | 18607AC | 18608AC |
| 18 x 72 | 18726AC | 18727AC | 18728AC |
| 24 x 36 | 24366AC | 24367AC | 24368AC |
| 24 x 48 | 24486AC | 24487AC | 24488AC |
| 24 x 60 | 24606AC | 24607AC | 24608AC |
| 24 x 72 | 24726AC | 24727AC | 24728AC |

E-Z ADJUSTER SHELF CHROME

| W" x L" | Model No. |
|---------|-----------|
| 18 x 36 | S1836AC |
| 18 x 48 | S1848AC |
| 18 x 60 | S1860AC |
| 18 x 72 | S1872AC |
| 24 x 36 | S2436AC |
| 24 x 48 | S2448AC |
| 24 x 60 | S2460AC |
| 24 x 72 | S2472AC |



REPOSITION SUSPENSION HOOKS TO ADJUST SHELVES IN SECONDS!



SOLID PLASTIC SHELVING

Conveniently helps you organize storage space in warehouses, stockrooms and in any work environment! Constructed of durable, rust and stain resistant plastic that cleans with ease. Raised lip, surrounding the edge of each shelf, prevents spills from overflowing. Shelves adjust in 1" increments on standard Nexel posts. Attach optional casters to move frequently used products to the work area as needed. 300 lb. capacity per shelf. Shelving unit consists of 4 solid plastic shelves and 4 posts. To order Casters, see page 13.

SHELVING UNIT

| W" x L" x H" | CHROME |
|--------------|-----------|
| | Model No. |
| 18 x 36 x 63 | 18366CSP |
| 24 x 48 x 63 | 24486CSP |
| 18 x 36 x 74 | 18367CSP |
| 24 x 48 x 74 | 24487CSP |

SHELVES

| W" x L" | Model No. |
|---------|-----------|
| 18 x 36 | S1836SP |
| 24 x 48 | S2448SP |

Plastic Mat Shelving



NEXELITE™ PLASTIC MAT SHELVING

Versatile storage system is perfect for storing all your goods, materials and inventory. Sturdy frame comes in **NEXELON** finish. Polymer composition shelf mats are of a modular design allowing easy removal for cleaning. They have a vented open grid surface that is smooth and crevice-free. Polymer material will never dent, chip, rust, or corrode. Open on all four sides for complete access and superior ventilation. Shelves adjust on 1" increments and have a up to a 600 lb. capacity. Shelving unit consists of 4 Nexelite shelves and 4 posts. Casters mobilize your storage system for quick and easy transportation. To order Casters, see page 13.

SHELVES -Consist of frame and tan plastic mats.

NEXELON NEXELITE SHELVING UNIT

| NEXELON | | NEXELON NEXELITE SHELVING UNIT | | | |
|---------|-----------|--------------------------------|--------------------|--------------------|--------------------|
| W" x L" | Model No. | W" x L" | 63" High Model No. | 74" High Model No. | 86" High Model No. |
| 18 x 30 | PM1830N | 18 x 30 | PM18306N | PM18307N | PM18308N |
| 18 x 36 | PM1836N | 18 x 36 | PM18366N | PM18367N | PM18368N |
| 18 x 42 | PM1842N | 18 x 42 | PM18426N | PM18427N | PM18428N |
| 18 x 48 | PM1848N | 18 x 48 | PM18486N | PM18487N | PM18488N |
| 18 x 54 | PM1854N | 18 x 54 | PM18546N | PM18547N | PM18548N |
| 18 x 60 | PM1860N | 18 x 60 | PM18606N | PM18607N | PM18608N |
| 18 x 72 | PM1872N | 18 x 72 | PM18726N | PM18727N | PM18728N |
| 24 x 30 | PM2430N | 24 x 30 | PM24306N | PM24307N | PM24308N |
| 24 x 36 | PM2436N | 24 x 36 | PM24366N | PM24367N | PM24368N |
| 24 x 42 | PM2442N | 24 x 42 | PM24426N | PM24427N | PM24428N |
| 24 x 48 | PM2448N | 24 x 48 | PM24486N | PM24487N | PM24488N |
| 24 x 54 | PM2454N | 24 x 54 | PM24546N | PM24547N | PM24548N |
| 24 x 60 | PM2460N | 24 x 60 | PM24606N | PM24607N | PM24608N |
| 24 x 72 | PM2472N | 24 x 72 | PM24726N | PM24727N | PM24728N |



SHELF MATS CAN BE REMOVED EASILY FOR CLEANING

LEDGES

Snaps onto perimeter of shelf providing 4"H retaining ledge. **POLYLBRITE** finish.

| Size" | Model No. | Size" | Model No. |
|-------|-----------|-------|-----------|
| 18 | PML18Z | 48 | PML48Z |
| 24 | PML24Z | 54 | PML54Z |
| 30 | PML30Z | 60 | PML60Z |
| 36 | PML36Z | 72 | PML72Z |
| 42 | PML42Z | | |

SHELF DIVIDERS

Installs easily without the use of bolts or nuts. high. **POLYLBRITE** finish.

| Size" | Model No. |
|----------------------|-----------|
| 18 | PMD18Z |
| 24 | PMD24Z |
| Extra Clips (16/Bag) | PMC16 |



LABEL HOLDER



3" LABEL HOLDER
Model No. | ABM3PM



Wire Bin Dump Shelving

SHOWN WITH TWO OPTIONAL DIVIDERS



SHOWN WITH OPTIONAL DIVIDERS

An easy access modular storage system that is both time and space efficient. Full view open design provides inventory control at a glance. Position side-by-side or back-to-back, stack 2 or 3 high for bench top use, stack up to 7 high for free-standing rack or use 14" and 20" deep lower bin with dolly for easy transport. Each bin has a 100 lb. capacity and can be separated into sub-compartments with dividers (sold separately). Industrial strength .283 dia. frame wire with .105 dia. cross wire construction ensures strength and rigidity, chrome finish. Assembles easily.

| W" x D" x H" | WIRE BINS Model No. | DIVIDERS† Model No. | |
|--------------|------------------------|------------------------|-----------------------------|
| 36 x 14 x 9 | WB3149 | WD149 | * 12"H bins have 9"H backs. |
| 48 x 14 x 9 | WB4149 | WD149 | |
| 36 x 20 x 9 | WB3209 | WD209 | † Sold 12 per carton |
| 48 x 20 x 9 | WB4209 | WD209 | |
| 36 x 20 x 12 | WB32012* | WD2012 | |
| 48 x 20 x 12 | WB42012* | WD2012 | |



SHOWN WITH OPTIONAL DIVIDERS AND DOLLY BASE

DOLLY BASE

Requires one 20" deep bottom bin. Equipped with four, smooth rolling 5" polyurethane wheel swivel casters

| Size" | Model No. |
|---------|---------------|
| 36 x 20 | WBD320 |
| 48 x 20 | WBD420 |

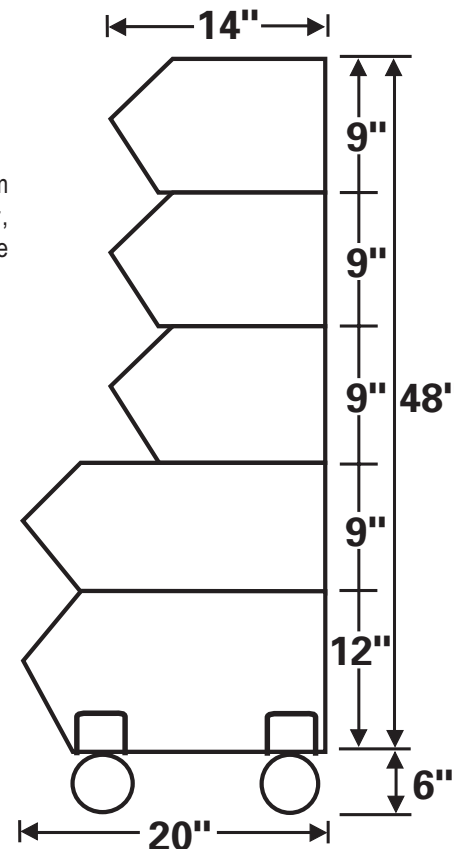

NOTE: If rigid or brake style casters are required for your application, order a starter shelving unit and casters separately.

Wall Mount Shelf Systems



SHELF BRACKETS

Perfect for creating wall storage area where floor space isn't available. One pair of wall brackets is required per shelf. Use Double Shelf brackets in a continuous run. Multi-Shelf brackets hold up to 3 shelves (with 4" clearance between shelves) 22" high overall. Chrome finish.



SINGLE SHELF BRACKET

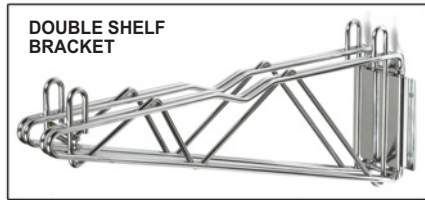

DOUBLE SHELF BRACKET

Single Shelf and Multi Shelf brackets are sold per pair. Double Shelf brackets are sold individually. Order shelves separately to length desired. 4 collar plugs included.

| WALL MOUNT SINGLE SHELF BRACKETS | | WALL MOUNT DOUBLE SHELF BRACKETS | |
|----------------------------------|-----------|----------------------------------|-----------|
| Size" | Model No. | Size" | Model No. |
| 14 | AB14C | 14 | DAB14C |
| 18 | AB18C | 18 | DAB18C |
| 21 | AB21C | 21 | DAB21C |
| 24 | AB24C | 24 | DAB24C |



MULTI-SHELF BRACKETS
HOLDS UP TO 3 SHELVES

| WALL MOUNT MULTI-SHELF BRACKETS | |
|---------------------------------|-----------|
| Size" | Model No. |
| 14 | WM14C |
| 18 | WM18C |

ADJUSTABLE SHELF BRACKETS

Adjustable Shelf Brackets allow you to adjust shelves on 1" increments. Shelves mount to posts individually or in as many tiers as needed. Choice of Single Shelf Bracket or Double Shelf Bracket. Use Double Shelf Bracket for assembling shelves in a continuous run. Double Shelf Bracket attaches to one post. Order one additional post kit for every 2 shelves. Post kit consists of 2 posts 4 wall brackets. Chrome finish.

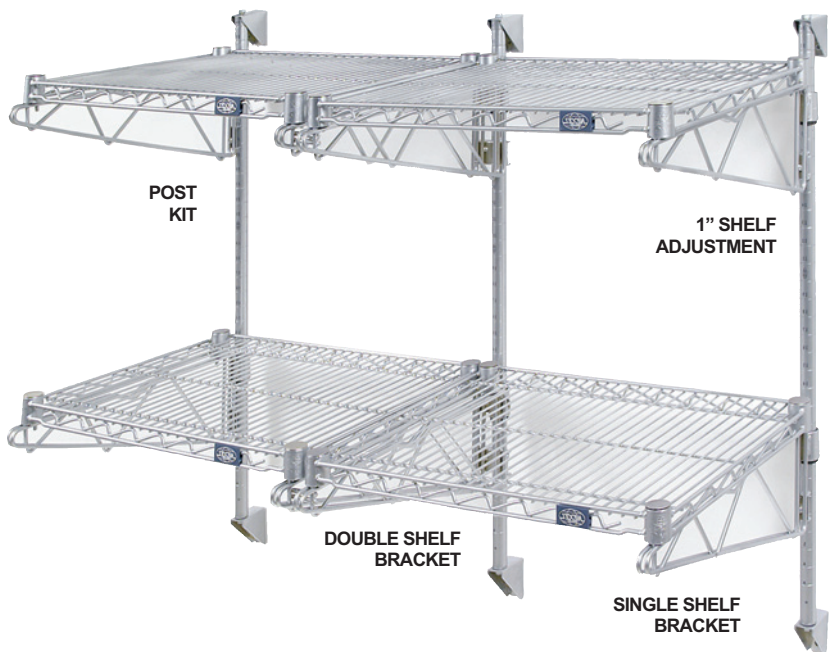

| DOUBLE SHELF BRACKETS (1 per carton) | | SINGLE SHELF BRACKETS (2 per carton) | |
|---|-----------|---|-----------|
| Size" | Model No. | Size" | Model No. |
| 14 | DPS14C | 14 | PS14C |
| 18 | DPS18C | 18 | PS18C |
| 24 | DPS24C | 24 | PS24C |

NOTE: USES STANDARD SHELVEING. ORDER SHELVES SEPARATELY. SEE PAGE 2. MOUNTING SCREWS NOT INCLUDED.



Space - Trac

HIGH DENSITY MOBILE STORAGE SYSTEM Maximize Your Storage with Minimum Floor Space



Double your storage space capacity instantly with this economical mobile shelving system. Provides instant access to inventory and allows maximum air and light circulation. **Space-Trac** is designed to eliminate unnecessary aisles, free-up floor space and increase the number of shelving units that can be used in a designated area. This is done by combining stationary and mobile units, to create or eliminate aisles as needed. The stainless steel overhead track assures smooth shifting of units, eliminates dirt and debris build-up that usually occurs with floor mounted systems and compensates for uneven floors. Both stationary and mobile units are available with a variety of shelf sizes. Mobile units have 5" polyurethane wheel casters. Simple installation makes this system practical and easy to use.

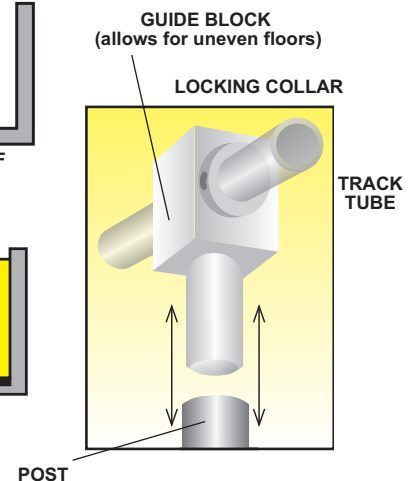
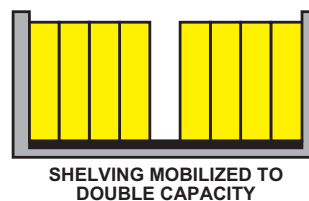
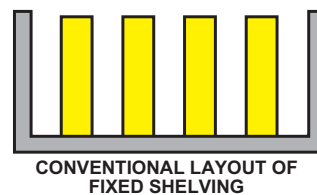
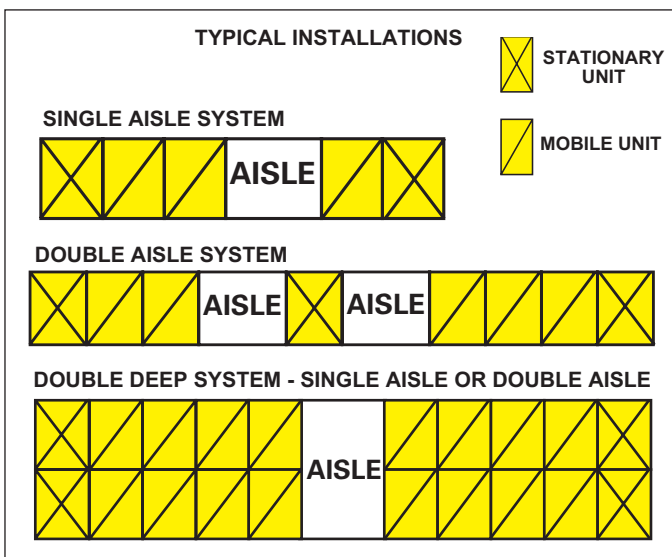

HOW TO ORDER: Simple to Install, Simple to Use

When choosing component parts, the following factors must be determined.

- 1 - The length of Space-Trac necessary.**
A-Combine the widths of necessary stationary and mobile units. Add minimum 30" for a single aisle and 2" for every mobile unit used to compensate for bumpers.
- 2 - The shelf length you want to work with** - all shelves must be same length. It is desirable that all shelves be the same width, but it is not required. For simplicity, if choosing different sizes, make stationary units one width and mobile units another.
- 3 - Height of Unit** - when choosing post height, all units must be same height.

4 - When ordering component parts remember:

- A** - Each **Stationary Unit** requires 1 stationary unit kit, 4 posts and shelves (you determine number).
WIRE SHELVES - order from page 2
SOLID SHELVES - order from page 3
- B** - Each **Mobile Unit** requires 1 mobile unit kit and shelves (you determine number).
- C** - **Space-Trac Guide Bar** (custom sized to a max. length of 12 ft.) for longer systems, order one Joining Insert to connect each additional guide bar ordered.

You must order a guide bar for the front and back length of the system.

Note: For double aisle and double deep systems check with Nexel for quote.

SAMPLE ORDER

What You Would Need To Order For Illustration Shown

A - 2 - Stationary Units

- Consist of: 8 #P86C Posts (4 per unit)
- 8 #S2148C Shelves (4 per unit)
- 2 #STS1 Stationary Unit Kits (1 per unit)

B - 3 - Mobile Units

- Consist of: 3 #STM861C Mobile Unit Kits (1 per unit)
- 12 #S2148C Shelves (4 per unit)

C - 24 Feet Space Trac Guide Bar

- Consists of: 2 #ST1030 Guide Bars @12 ft. each, equals 24 ft.

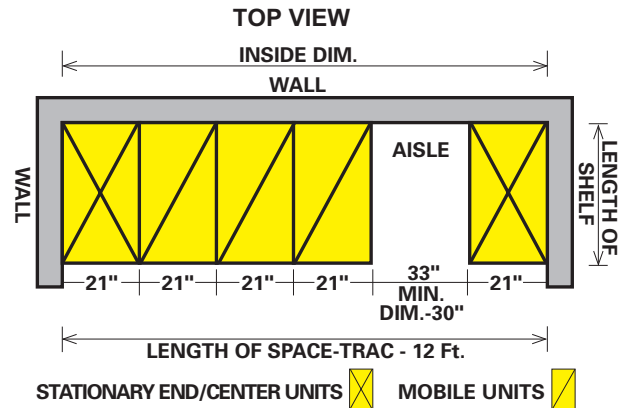

STATIONARY UNIT KIT Model No. STS1

Consists of the following parts:

- 4 Guide Blocks
- 4 Locking Collars
- 4 Foot Plates

MOBILE UNIT KIT - order shelves separately to match the width of mobile units.

Consists of the following parts:

- 4 Guide Blocks
- 4 Posts
- 4 Casters
- 2 Tie Bars

| Width" | Overall Height" | CHROME |
|--------|-----------------|---------|
| 18 | 76 | STM748C |
| 18 | 88 | STM868C |
| 21 | 76 | STM741C |
| 21 | 88 | STM861C |
| 24 | 76 | STM744C |
| 24 | 88 | STM864C |

POSTS - for Stationary End/Center Units
CHROME
 Overall Height" Model No.

| | |
|----|------|
| 76 | P74C |
| 88 | P86C |

WIRE SHELVES - order from page 2

SOLID SHELVES - order from page 3

SPACE-TRAC GUIDE BAR - specify required length and order required joining inserts - see example of 16 ft. run.

Model No. **ST1030**

SPACE-TRAC GUIDE BAR CAP - Model No. **ST1060**

JOINING INSERT Model No. ST1040

Maximum length of Space-Trac guide bar is 12 feet. If a longer length is required, you must order one joining insert for each length to be connected.

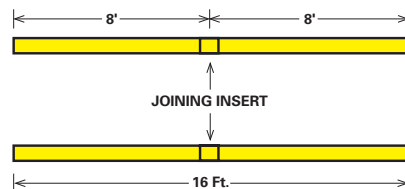

Example of a 16 ft. run

This requires four - 8' Space-Trac guide bars (#ST1030) and two - joining inserts (#ST1040) to create the desired 16 ft. run.



Parts & Accessories



DISPOSABLE GLOVE HOLDER

Use as either a wall mount unit or as an accessory to utility carts. Chrome finish.
Model No. **AGH**

LABEL HOLDER

| Length* | Color | Model No. | Length* | Color | Model No. |
|---------|-------|--------------|---------|-------|---------------|
| 3 | Black | ABM3 | 12 | Clear | ABM12C |
| 3 | Clear | ABM3C | 24 | Clear | ABM24C |



LARGE 1 1/2" SHELF COLLAR HOOK
Model No. **SSB2C**



SMALL 1/2" SHELF COLLAR HOOK
Model No. **SSB1C**



UTILITY BASKET
Model No. **ASW177** 17 3/8" x 7 1/2" x 10"H.



DOCUMENT HOLDER
Model No. **AH** 12 3/8" x 2" x 8 5/8"H



LOCKING POST COLLAR
Model No. **APL**



SHELF COLLAR PLUG
Model No. **AL**
Use on shelf collar.



POST CAP
Model No. **AP**
Use on top of post.



RUBBER Mallet
Model No. **ARM**



POST CLAMP
Securely joins two sections together.
Width* Model No.
1 1/16" **AC**
3 1/16" **ACX**



WALL MOUNTING BRACKET
Model No. **AW2C**
Secures posts to wall - 2" clearance.



SHELF CLIP (4 PAIR)
Model No. **AM**



"S" HOOK
Model No. **AS** - Use 2 for each add-on wire shelf. Sold 8 per package



NON-MARRING FLOOR GLIDE
Model No. **AG**



POST LEVELER BOLT & INSERT
Model No. **AX**



3 1/2" DONUT BUMPER
Model No. **AB3**



FOOT PLATE
Model No. **AF**

SAFETY PUSH HANDLES

Make maneuvering simple. Safety push handle keeps hands within cart width preventing bumps with walls and objects. Chrome finish.



| Width" | Model No. |
|--------|-----------|
| 18 | AE18C |
| 21 | AE21C |
| 24 | AE24C |

UTILITY CART HANDLES

Offset tubular handle constructed of 1" steel tubing, grooved on 1" increments for easy shelf adjustment. 33"H. Chrome finish.



| Width" | Model No. |
|--------|-----------|
| 18 | AH18C |
| 21 | AH21C |
| 24 | AH24C |

LEDGES

Protect your valuable inventory. Ledges help keep items from falling off edge of shelf. Snaps onto perimeter of shelf creating 4"H retaining edge. If higher ledge is required, stack for 8", 12" etc. Chrome finish.



| Size" | Model No. |
|-------|-----------|
| 14 | AL414C |
| 18 | AL418C |
| 21 | AL421C |
| 24 | AL424C |
| 30 | AL430C |
| 36 | AL436C |
| 42 | AL442C |
| 48 | AL448C |
| 54 | AL454C |
| 60 | AL460C |
| 72 | AL472C |

TRAY SLIDE INSERTS



Ideal for use on shelving, trucks and carts. Tray Slide Inserts save valuable space by allowing you to suspend trays and tote pans between shelves. Slides fit between any 18" or 24" deep wire shelves when spaced 22" apart. Slides adjust on 1/2" centers. Chrome finish.

| MULTI-TRAY | | MODU-BOX | |
|------------|-----------|--------------|-----------|
| Size" | Model No. | L" x W" x H" | Model No. |
| 18 | AT18C | 16 x 11 x 5 | TB165 |
| 24 | AT24C | 22 x 17 x 5 | TB225 |
| | | 22 x 17 x 6 | TB226 |
| | | 22 x 17 x 8 | TB228 |
| | | 24 x 11 x 8 | TB248 |

Single - Tray Slide Insert. Attach a tray below wire 18" or 24" shelf with easy to install brackets to create a slide-out drawer.

Model No. | **AST24C**

SHELF DIVIDERS

Installs easily without the use of bolts, nuts or clips. Attaches at any point along shelf. 8" high. Chrome finish.

| Size" | Model No. |
|-------|-----------|
| 14 | AD814C |
| 18 | AD818C |
| 21 | AD821C |
| 24 | AD824C |

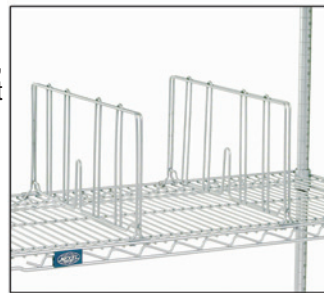

RODS & CLIPS

Enclose back and/or sides of shelving easily with rods and clips. Each kit contains 1 rod, 4 front/back flips (AT) and 4 side clips (SRT) that allow you to attach rods at desired spaces. Chrome finish.

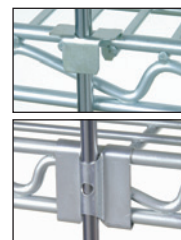

FRONT/BACK CLIP
Model No. **AT**

SIDE CLIP
Model No. **SRT**

| Length" | Model No. |
|---------|-----------|
| 52 | AR54C |
| 61 | AR63C |
| 72 | AR74C |
| 84 | AR86C |

ADDITIONAL CLIP

Order additional clips for units with more than four shelves.

Front/Back. | **AT**
Side. | **SRT**



HANGER RAILS

Hanging Rail can be mounted along the length or width of shelving unit. Hooks can be easily attached to Hanger Rails. Chrome finish.

| Size" | Model No. | Size" | Model No. |
|-------|-----------|-------|-----------|
| 18 | AHR18C | 48 | AHR48C |
| 24 | AHR24C | 60 | AHR60C |
| 36 | AHR36C | 72 | AHR72C |

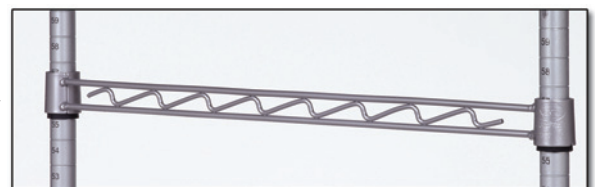



Parts & Accessories

CART COVERS



COVERS ENTIRE CART/TRUCK



PANEL FOLDS BACK FOR EASY SHELF ACCESSIBILITY



10 GAGE CLEAR VINYL

Helps keep contents dust and dirt free. Made of water resistant, 400 denier nylon or 10 gage vinyl with reinforced corners and double stitching for maximum durability. Velcro or zipper closure. **Specify color suffix (RD) Red, (BL) Blue, (WH) White or (CL) Clear, when ordering. Special orders upon request.**

| Cover L" x H" | Model For Use With | | Cover L" x H" | Model For Use With | |
|---------------|------------------------|------------------------|---------------|------------------------|------------------------|
| | 18"W Unit | 24"W Unit | | 18"W Unit | 24"W Unit |
| 36 x 63 | CO1836 | CO2436 | 36 x 74 | CO1837 | CO2437 |
| 48 x 63 | CO1846 | CO2446 | 48 x 74 | CO1847 | CO2447 |
| 60 x 63 | CO1856 | CO2456 | 60 x 74 | CO1857 | CO2457 |
| 72 x 63 | CO1866 | CO2466 | 72 x 74 | CO1867 | CO2467 |

SHELF MATS



Keep items from falling through open shelving. Durable .035 clear Polyethelene sheet that can be removed easily for cleaning.

| CLEAR POLYETHYLENE Size" | Model No. |
|--------------------------|--------------------------|
| 18 x 36 | SM1836CL |
| 18 x 48 | SM1848CL |
| 18 x 60 | SM1860CL |
| 18 x 72 | SM1872CL |
| 24 x 36 | SM2436CL |
| 24 x 48 | SM2448CL |
| 24 x 60 | SM2460CL |
| 24 x 72 | SM2472CL |

UPRIGHT EXTENSION KIT

Extend the height of your shelving unit instantly. Upright Extension Kit allows you to increase your shelving unit up to a maximum of 140". Extended units must be securely anchored to wall with mounting brackets, kit converts two posts. Two post kit includes two threaded post inserts, two double threaded bolts and four wall mounting brackets. Mounting screws not included.

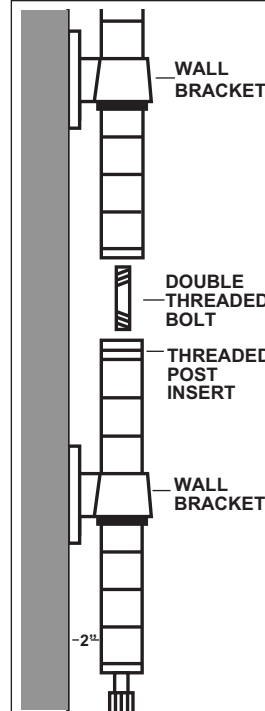

Model No. | [AX4C](#)

Casters & Dollies



Description: Black Nylon Twin Wheel, 1 3/4" x 2", 90 lb. capacity. 3/8"-16 Threaded Stem. Fits Standard Leveler Inserts.

| Type | Model No. |
|------------------------------|-----------|
| Swivel, 2 w/Brake (Set of 4) | CA2BN4 |

Description: Resilient Rubber Wheel, 1 1/4" x 5", 200 lb. capacity.

| Type | Model No. |
|-----------------------------|-----------|
| Swivel (Set of 4) | CA5S4R |
| Swivel w/Brake (Set of 4) | CA5BR4 |
| Swivel 2 w/Brake (Set of 4) | CA5SBR |

Description: Polyurethane Wheel, 1 1/4" x 5", 300 lb. capacity

| Type | Model No. |
|---|-----------|
| Swivel (Set of 4) | CA5S4 |
| Swivel w/Brake (Set of 4) | CA5BP4 |
| Swivel, 2 w/Brake (Set of 4) | CA5SB |
| Swivel, 2 w/Brake, 2 Rigid (Set of 4) | CA5RSB* |
| Stainless Steel, Swivel, 2 w/Brake (Set of 4) | CA5SBS |

Description: Pneumatic Wheel, 2.5" x 8", 300 lb. capacity.

| Type | Model No. |
|------------------------------|-----------|
| 2 Swivel, 2 Rigid (Set of 4) | CA85RN* |

STEM CASTERS



DONUT BUMPER



BLACK NYLON



RUBBER SWIVEL



RUBBER SWIVEL WITH BRAKE



POLYURETHANE SWIVEL



POLYURETHANE SWIVEL WITH BRAKE



POLYURETHANE RIGID



PNEUMATIC SWIVEL

Note: Load capacity ratings are per caster. All Stem casters include donut bumpers, (except CA2BN4.) *Requires Tie Bar-See Below

TIE BARS

Rigid Stem Casters require the use of a tie bar to assure rigid caster alignment. The bar connects the casters across the narrow width dimension of the cart or truck. For every two casters ordered, one tie bar must be used. Finished in chrome. The bar size must match shelf width.

| Size" | Model No. |
|-------|-----------|
| 18 | ATB18 |
| 21 | ATB21 |
| 24 | ATB24 |



PLATE CASTERS

| Type | Model No. | Wheel Size" | Plate Size** | Wheel Tread | Load Rating (lbs.) |
|----------------|-----------|-------------|---------------|--------------|--------------------|
| Swivel | ACP5SP | 5 x 1 1/4 | 4 1/2 x 3 3/4 | Polyurethane | 300 |
| Swivel w/Brake | ACP5BP | 5 x 1 1/4 | 4 1/2 x 3 3/4 | Polyurethane | 300 |
| Rigid | ACP5RP | 5 x 1 1/4 | 4 1/2 x 3 3/4 | Polyurethane | 300 |
| Swivel | ACP8SR | 8 x 2 | 4 x 4 1/2 | Pneumatic | 300 |
| Rigid | ACP8RR | 8 x 2 | 4 x 4 1/2 | Pneumatic | 300 |

Note: For overall height add approximately 1 1/2" to wheel size. Add 3" for 8" caster. * 2 5/8" x 3 5/8" bolt spacing on mounting plates



POLYURETHANE SWIVEL



POLYURETHANE RIGID



POLYURETHANE SWIVEL WITH BRAKE



PNEUMATIC SWIVEL



PNEUMATIC RIGID

DOLLY BASES

Allows you to create a heavy duty, mobile shelving unit or cart. Constructed of durable formed steel, chrome plated finish. Includes corner bumpers. Plate casters must be ordered separately.

| W" x L" | Model No. |
|---------|-----------|
| 18 x 36 | DBC1836 |
| 18 x 48 | DBC1848 |
| 18 x 60 | DBC1860 |
| 24 x 36 | DBC2436 |
| 24 x 48 | DBC2448 |
| 24 x 60 | DBC2460 |
| 30 x 36 | DBC3036 |
| 30 x 48 | DBC3048 |





Wire Shelf Trucks

STEM CASTER TRUCK



SHOWN WITH OPTIONAL LEDGES, DIVIDERS, DOCUMENT HOLDER AND SAFETY HANDLE

Provides high visibility and easy 4-way access. Ensures quick and efficient inventory control. Ideal for mobile storage requirements. Allows air to circulate throughout, eliminating dust and dirt build-up. Allows you to keep linens, food items, stocked products and other regularly used items on hand, throughout the workplace.

Locking post collars are recommended for rough use over the road vibration and jolting. Order one per shelf. Part No. APL. See page 10.

CHROME

| Size W" x L" | Rubber Wheel Casters Model No. | Polyurethane Wheel Casters Model No. | Pneumatic Wheel Casters Model No. |
|-----------------|--------------------------------------|--|---|
| 18 x 36 | C1836RC | C1836PC | C1836NC |
| 18 x 48 | C1848RC | C1848PC | C1848NC |
| 18 x 60 | C1860RC | C1860PC | C1860NC |
| 21 x 36 | C2136RC | C2136PC | C2136NC |
| 21 x 48 | C2148RC | C2148PC | C2148NC |
| 21 x 60 | C2160RC | C2160PC | C2160NC |
| 24 x 36 | C2436RC | C2436PC | C2436NC |
| 24 x 48 | C2448RC | C2448PC | C2448NC |
| 24 x 60 | C2460RC | C2460PC | C2460NC |

NOTE: If rigid or brake style casters are required for your application, order a starter shelving unit and casters separately.

DOLLY BASE TRUCK



SHOWN WITH OPTIONAL LEDGES, DIVIDER AND 8" PNEUMATIC WHEELS

Truck consists of 4 posts, 4 shelves, plastic shelf clips, truck dolly with corner rubber bumper and two swivel and two rigid casters. Posts are 63"H. Available with 6" resilient rubber wheel plate casters that have a 800 lb. load capacity, 5" polyurethane wheel plate casters that have a 1200 lb. load capacity or 8" pneumatic wheel plate casters with a 1200 lb. load capacity. Dolly base is heavy duty steel. Chrome finish.

CHROME

| Size W" x L" | Rubber Wheel Casters Model No. | Polyurethane Wheel Casters Model No. | Pneumatic Wheel Casters Model No. |
|-----------------|--------------------------------------|--|---|
| 18 x 36 | D1836RC | D1836PC | D1836NC |
| 18 x 48 | D1848RC | D1848PC | D1848NC |
| 18 x 60 | D1860RC | D1860PC | D1860NC |
| 24 x 36 | D2436RC | D2436PC | D2436NC |
| 24 x 48 | D2448RC | D2448PC | D2448NC |
| 24 x 60 | D2460RC | D2460PC | D2460NC |



STEM CASTER TRUCK

Keep linens, food items, stocked products and other regularly used items on hand, throughout the workplace. Ideal for mobile storage requirements. Easy 4-way access and visibility. Ensures quick and efficient inventory control. **Truck** consists of 4 posts, 4 solid shelves, plastic shelf clips, donut bumpers and 5" dia. swivel casters. Posts are 63"H. Overall truck height is 69". Casters are available in resilient rubber wheel stem casters that have an 800 lb. load capacity or polyurethane wheel stem casters that have a 1200 lb. load capacity.

NOTE: If rigid, brake or larger casters are required for your application, order a starter shelving unit and casters separately.

| Size W" x L" | Rubber Wheel Casters | | | | Polyurethane Casters | | | |
|-----------------|---------------------------|---------------------------------|-------------------------------|---------------------------------|---------------------------|---------------------------------|-------------------------------|---------------------------------|
| | Four Swivel | | Four Swivel (2 with brake) | | Four Swivel | | Four Swivel (2 with brake) | |
| | Poly-Z-Brite Model No. | Stainless Steel Model No. | Poly-Z-Brite Model No. | Stainless Steel Model No. | Poly-Z-Brite Model No. | Stainless Steel Model No. | Poly-Z-Brite Model No. | Stainless Steel Model No. |
| 18 x 36 | C1836RZ4 | C1836RS4 | C1836RZ2 | C1836RS2 | C1836PZ4 | C1836PS4 | C1836PZ2 | C1836PS2 |
| 18 x 48 | C1848RZ4 | ----- | C1848RZ2 | ----- | C1848PZ4 | ----- | C1848PZ2 | ----- |
| 18 x 60 | C1860RZ4 | ----- | C1860RZ2 | ----- | C1860PZ4 | ----- | C1860PZ2 | ----- |
| 18 x 72 | C1872RZ4 | ----- | C1872RZ2 | ----- | C1872PZ4 | ----- | C1872PZ2 | ----- |
| 24 x 36 | C2436RZ4 | C2436RS4 | C2436RZ2 | C2436RS2 | C2436PZ4 | C2436PS4 | C2436PZ2 | C2436PS2 |
| 24 x 48 | C2448RZ4 | C2448RS4 | C2448RZ2 | C2448RS2 | C2448PZ4 | C2448PS4 | C2448PZ2 | C2448PS2 |
| 24 x 60 | C2460RZ4 | ----- | C2460RZ2 | ----- | C2460PZ4 | ----- | C2460PZ2 | ----- |
| 24 x 72 | C2472RZ4 | ----- | C2472RZ2 | ----- | C2472PZ4 | ----- | C2472PZ2 | ----- |



SHOWN WITH OPTIONAL LEDGES, DIVIDERS, SAFETY HANDLE AND DOCUMENT HOLDER



DOLLY BASE TRUCK

Engineered to handle daily abuse for a lifetime of use. Durable construction answers a variety of material handling, food service and health facility needs. Dolly base is heavy duty steel, chrome plated, and provides maximum stability. **Truck** consists of 4 posts, 4 solid shelves, plastic shelf clips, truck dolly with rubber corner bumper and 5" dia. swivel casters. Posts are 63"H. Overall truck height is 69". Casters are available in resilient rubber wheel plate casters that have a 1000 lb. load capacity or polyurethane plate casters that have a 1200 lb. load capacity.

NOTE: If rigid, brake or larger casters are required for your application, order shelves, posts, dolly base and casters separately as components.

| Size W" x L" | Rubber Wheel Casters | | | | Polyurethane Casters | | | |
|-----------------|---------------------------|---------------------------------|-------------------------------|---------------------------------|---------------------------|---------------------------------|-------------------------------|---------------------------------|
| | Four Swivel | | Four Swivel (2 with brake) | | Four Swivel | | Four Swivel (2 with brake) | |
| | Poly-Z-Brite Model No. | Stainless Steel Model No. | Poly-Z-Brite Model No. | Stainless Steel Model No. | Poly-Z-Brite Model No. | Stainless Steel Model No. | Poly-Z-Brite Model No. | Stainless Steel Model No. |
| 18 x 36 | D1836RZ4 | D1836RS4 | D1836RZ2 | D1836RS2 | D1836PZ4 | D1836PS4 | D1836PZ2 | D1836PS2 |
| 18 x 48 | D1848RZ4 | ----- | D1848RZ2 | ----- | D1848PZ4 | ----- | D1848PZ2 | ----- |
| 18 x 60 | D1860RZ4 | ----- | D1860RZ2 | ----- | D1860PZ4 | ----- | D1860PZ2 | ----- |
| 24 x 36 | D2436RZ4 | D2436RS4 | D2436RZ2 | D2436RS2 | D2436PZ4 | D2436PS4 | D2436PZ2 | D2436PS2 |
| 24 x 48 | D2448RZ4 | D2448RS4 | D2448RZ2 | D2448RS2 | D2448PZ4 | D2448PS4 | D2448PZ2 | D2448PS2 |
| 24 x 60 | D2460RZ4 | ----- | D2460RZ2 | ----- | D2460PZ4 | ----- | D2460PZ2 | ----- |





Utility Carts

WIRE UTILITY CARTS

Multi-purpose cart can store and transport packages, inventory, linens or supplies. Easy to handle cart can be maneuvered through corridors and doorways without difficulty. Shelves adjust on 1" increments for added versatility.

Cart consists of 2 chrome-plated "U" shaped handles, 2 or 3 shelves (as indicated), plastic shelf clips, choice of caster and donut bumpers. Casters are available in resilient rubber wheel casters with a capacity of 800 lbs., polyurethane wheel casters that have a 1200 lb. load capacity and 8" full pneumatic wheels with a capacity of 1200 lbs. Rubber and polyurethane casters come packaged as 4 swivel stem casters. Full pneumatic comes packed as 2 rigid and 2 swivel casters. Chrome finish.



TWO SHELF CART SHOWN WITH OPTIONAL LEDGES, GLOVE HOLDER AND DIVIDER



TWO SHELF MODELS

THREE SHELF MODELS

| Size W" x L" | Rubber Wheel Casters | Polyurethane Wheel Casters | Pneumatic Wheel Casters | Rubber Wheel Casters | Polyurethane Wheel Casters | Pneumatic Wheel Casters |
|-----------------|----------------------------|----------------------------------|-------------------------------|----------------------------|----------------------------------|-------------------------------|
| | Model No. | Model No. | Model No. | Model No. | Model No. | Model No. |
| 18 x 30 | 1830R2C | 1830P2C | 1830N2C | 1830R3C | 1830P3C | 1830N3C |
| 18 x 36 | 1836R2C | 1836P2C | 1836N2C | 1836R3C | 1836P3C | 1836N3C |
| 18 x 42 | 1842R2C | 1842P2C | 1842N2C | 1842R3C | 1842P3C | 1842N3C |
| 21 x 30 | 2130R2C | 2130P2C | 2130N2C | 2130R3C | 2130P3C | 2130N3C |
| 21 x 36 | 2136R2C | 2136P2C | 2136N2C | 2136R3C | 2136P3C | 2136N3C |
| 21 x 42 | 2142R2C | 2142P2C | 2142N2C | 2142R3C | 2142P3C | 2142N3C |
| 21 x 48 | 2148R2C | 2148P2C | 2148N2C | 2148R3C | 2148P3C | 2148N3C |
| 24 x 30 | 2430R2C | 2430P2C | 2430N2C | 2430R3C | 2430P3C | 2430N3C |
| 24 x 36 | 2436R2C | 2436P2C | 2436N2C | 2436R3C | 2436P3C | 2436N3C |
| 24 x 42 | 2442R2C | 2442P2C | 2442N2C | 2442R3C | 2442P3C | 2442N3C |
| 24 x 48 | 2448R2C | 2448P2C | 2448N2C | 2448R3C | 2448P3C | 2448N3C |
| 24 x 60 | 2460R2C | 2460P2C | 2460N2C | 2460R3C | 2460P3C | 2460N3C |

NSF®

GALVANIZED OR STAINLESS STEEL UTILITY CART



SHOWN WITH OPTIONAL SHELF DIVIDERS AND LEDGES

2 SHELF

| Size W" x L" | Galvanized | Stainless |
|-----------------|------------|-----------|
| | Model No. | Model No. |
| 18 x 36 | 1836P2SZ | 1836P2SS |
| 24 x 36 | 2436P2SZ | 2436P2SS |
| 24 x 48 | 2448P2SZ | 2448P2SS |

3 SHELF

| Size W" x L" | Galvanized | Stainless |
|-----------------|------------|-----------|
| | Model No. | Model No. |
| 18 x 36 | 1836P3SZ | 1836P3SS |
| 24 x 36 | 2436P3SZ | 2436P3SS |
| 24 x 48 | 2448P3SZ | 2448P3SS |

SHELF LEDGES

| Length" | Model No. |
|---------|-----------|
| 18 | SL18C |
| 24 | SL24C |
| 36 | SL36C |
| 48 | SL48C |

SHELF DIVIDERS

| Length" | Model No. |
|---------|-----------|
| 18 | SD18C |
| 24 | SD24C |

Shelf & Utility Carts



ADJUSTABLE SHELF CART

Chrome Plated Wire or Galvanized Solid Steel Shelves

Super-strong cart stores and transports safely and efficiently. Ideal for warehouse, lab, factory, hospital and more. Shelves adjust on 1" increments. Numbered posts allow quick positioning at desired height. 5" polyurethane wheel swivel casters with donut bumpers. 800 lb. capacity. Overall height for all carts is 40".

| W"x L" | WIRE Model No. | SOLID Model No. |
|---------|----------------|-----------------|
| 18 x 36 | SC18363 | SC1836SZ |
| 18 x 48 | SC18483 | SC1848SZ |
| 18 x 60 | SC18603 | SC1860SZ |
| 18 x 72 | SC18723 | SC1872SZ |
| 24 x 36 | SC24363 | SC2436SZ |
| 24 x 48 | SC24483 | SC2448SZ |
| 24 x 60 | SC24603 | SC2460SZ |
| 24 x 72 | SC24723 | SC2472SZ |



SOLID PLASTIC SHELF UTILITY CARTS

Solid Shelf Cart consists of 2 chrome plated handles, 2 or 3 solid plastic shelves and a choice of rubber or polyurethane swivel casters, 2 with brake. Solid plastic shelves are made of durable, rust and stain resistant plastic, that cleans with ease. Raised lip, along edge of shelf, prevents spills from overflowing.

SOLID SHELF UTILITY CART - 2 SHELF

| W"x L" | Rubber Wheel Caster | Polyurethane Wheel Caster |
|---------|---------------------|---------------------------|
| | Model No. | Model No. |
| 18 x 36 | 1836R2SP | 1836P2SP |
| 24 x 48 | 2448R2SP | 2448P2SP |

SOLID SHELF UTILITY CART - 3 SHELF

| W"x L" | Rubber Wheel Caster | Polyurethane Wheel Caster |
|---------|---------------------|---------------------------|
| | Model No. | Model No. |
| 18 x 36 | 1836R3SP | 1836P3SP |
| 24 x 48 | 2448R3SP | 2448P3SP |



STAINLESS STEEL UTILITY CART

400 lb. capacity

Ideal for use in clean rooms, restaurants and other corrosive environments. Premium 304 polished stainless steel throughout, with 20 gauge shelves and strong 16 gauge shelf uprights for years of service. 24"L x 15"W x 33"H with 12" clearance between shelves. Top and middle shelves have 1 1/4" lips on 3 sides to help retain cargo during transit, while flush lower shelf is ideal for oversized items. Comfortable tubular push handle. Rolls smoothly on four 4" swivel non-marring rubber casters, 2 with brakes.

Model No. | **SSC1524**





Security Units

WIRE SECURITY SHELVING & TRUCKS

Look to NEXEL for a safer and more secure way to store valuable equipment and supplies. Open 2" square grid mesh ensures high visibility, while lockable double door (opens a full 270°) keeps contents protected. Security units feature adjustable levelers and assemble easily. Available in Chrome. All units are 66" high with top and bottom shelf.

NOTE: Available accessories include: Shelf Dividers, Foot Plates, and Tray Slide Inserts

| CHROME | | Optional Interior Shelf Model No. |
|---------|-------------------------|-----------------------------------|
| W" x L" | Model No. | |
| 18 x 36 | SU1836C | S1836AC |
| 18 x 48 | SU1848C | S1848AC |
| 24 x 36 | SU2436C | S2436AC |
| 24 x 48 | SU2448C | S2448AC |
| 24 x 60 | SU2460C | S2460AC |

2 SIDE PANELS & BACK

| W" x L" x H" | Model No. |
|--------------|-------------------------|
| 18 x 36 x 59 | SP3618C |
| 18 x 48 x 59 | SP4818C |
| 24 x 36 x 59 | SP2436C |
| 24 x 48 x 59 | SP2448C |
| 24 x 60 x 59 | SP2460C |

DOOR SET

| W" x L" x H" | Model No. |
|--------------|--------------------------|
| 18 x 36 x 59 | SD3618C* |
| 18 x 48 x 59 | SD4818C* |
| 24 x 36 x 59 | SD36C |
| 24 x 48 x 59 | SD48C |
| 24 x 60 x 59 | SD60C |

* Use with 18" Back and Sides Only



SHOWN WITH ONE OPTIONAL SHELF



FOLD-UP SECURITY TRUCK

Help protect inventory from theft and damage with this completely enclosed truck. Open construction reduces dust accumulation and increases visibility. Fold to 6" for compact storage. Heavy gauge wire mesh and 1" square tubing finished in high quality gray epoxy. Solid center shelf divides truck into two 34"H compartments and increases strength of unit. 2 rigid and 2 swivel 6" x 2" molded on rubber wheel casters increase mobility. 44 1/2" x 27" x 75"H. 2000 lb. capacity. Padlockable.

Model No. | [STF2000](#)



Security Units



MODEL STS2448C SHOWN WITH 1 OPTIONAL INTERIOR SHELF AND DOCUMENT HOLDER

STANDARD UNIT - Features stem casters with 3" donut bumpers.



MODEL STH2448C SHOWN WITH 2 OPTIONAL INTERIOR SHELVES

HEAVY DUTY UNIT - Features rugged dolly base platform with plate casters and corner bumpers.

These 1200 lb. capacity Security Trucks feature the same quality construction as the stationary security units on the previous page. Keep valuable items such as pharmaceuticals, syringes and expensive instruments secure and at the same time be able to transport them throughout your facility. Lockable doors prevent items from falling out of truck while in transit. 5" polyurethane wheel swivel casters. Compact size makes it ideal for permanent inventory storage. 69"H. Chrome finish.

SECURITY TRUCKS

| W" x L" | Style | Chrome Model No. |
|---------|------------|--------------------------|
| 18 x 36 | Standard | STS1836C |
| 18 x 36 | Heavy Duty | STH1836C |
| 18 x 48 | Standard | STS1848C |
| 18 x 48 | Heavy Duty | STH1848C |
| 24 x 36 | Standard | STS2436C |
| 24 x 36 | Heavy Duty | STH2436C |
| 24 x 48 | Standard | STS2448C |
| 24 x 48 | Heavy Duty | STH2448C |
| 24 x 60 | Standard | STS2460C |
| 24 x 60 | Heavy Duty | STH2460C |

OPTIONAL INTERIOR SHELVES

| W" x L" | Chrome Model No. |
|---------|-------------------------|
| 18 x 36 | S1836AC |
| 18 x 48 | S1848AC |
| 24 x 36 | S2436AC |
| 24 x 48 | S2448AC |
| 24 x 60 | S2460AC |

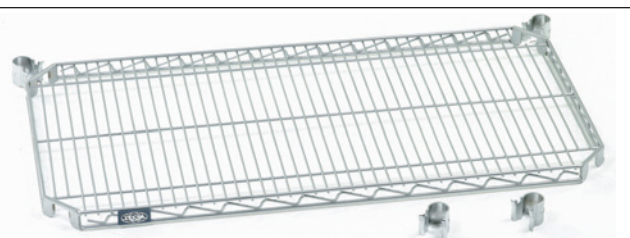

Optional E-Z Adjuster Shelves allow for shelf adjustment, removal or addition without disassembling the entire unit. Just lift off shelf and reposition to desired height.



TOTE BOXES & BINS

STACKABLE PLASTIC BIN



Use throughout your facility to keep, small inventory items organized, and easily accessible. Stackable for compact storage. Heavy duty injection molded polypropylene construction features reinforced walls for rigidity. Water, rust and corrosion resistant. Bins come in a choice of colors. Add suffix (Y) Yellow, (B) Blue.

| W" x D" x H" | Carton Quantity | Model No. | Transparent Cover Model No. | Divider Model No. |
|---------------------|-----------------|-----------|-----------------------------|-------------------|
| 4 1/8 x 4 1/2 x 3 | 48 | PB44 | --- | PD44 |
| 4 1/8 x 5 1/2 x 3 | 48 | PB45 | TC45 | PD45 |
| 4 1/8 x 7 1/2 x 3 | 24 | PB47 | TC47 | PD47 |
| 5 1/2 x 11 x 5 | 12 | PB511 | TC511 | PD511 |
| 11 x 11 x 5 | 6 | PB1111* | --- | PD511 |
| 8 1/4 x 11 x 7 | 6 | PB811* | --- | PD811 |
| 8 1/4 x 14 3/4 x 7 | 12 | PB814* | --- | PD814 |
| 16 1/2 x 14 3/4 x 7 | 6 | PB1614* | --- | PD1614 |

* Accommodates 3 Dividers

- WIDE LEDGE ENSURES STACKING STABILITY
- EXTRA LARGE LABEL AREA
- FINGER GRIPS ENSURE SAFE HANDLING



MINI BIN

MINI-BINS

Fits inside larger bins to create small compartments. Simplifies parts storage, removal and assembly. Yellow only.

| W" x D" x H" | Carton Quantity | Model No. |
|---------------|-----------------|-----------|
| 2 x 3 1/4 x 3 | 100 | MB32 |
| 2 x 5 1/4 x 3 | 50 | MB53 |
| 4 x 2 x 4 | 50 | MB42 |



DIVIDABLE MODU-BOX

Maximize storage space with these dividable, stackable heavy duty boxes. Constructed of ribbed, injection molded gray polyethylene for strength and rigidity. Easy to clean. Optional Dividers fit in molded-in grooves, on 1 1/4" centers. Optional Lids are made of clear plastic allowing contents to remain secure and visible for inventory control.



BOXES

DIVIDERS

| W" x D" x H" | Model No. | Short Model No. | Qty. | Long Model No. | Qty. |
|-----------------|-----------|-----------------|------|----------------|------|
| 11 x 8 x 2 1/2 | TB112 | TB112S | 7 | TB112L | 5 |
| 11 x 8 x 3 1/2 | TB113 | TB113S | 7 | TB113L | 5 |
| 11 x 8 x 4 1/2 | TB114 | TB114S | 7 | TB114L | 5 |
| 11 x 8 x 5 | TB115 | TB115S | 7 | TB115L | 5 |
| 16 x 11 x 1 3/4 | TB161 | TB161S | 11 | TB161L | 7 |
| 16 x 11 x 2 1/2 | TB162 | TB162S | 11 | TB162L | 7 |
| 16 x 11 x 3 1/2 | TB163 | TB163S | 11 | TB163L | 7 |
| 16 x 11 x 4 1/2 | TB164 | TB164S | 11 | TB164L | 7 |
| 16 x 11 x 5 | TB165 | TB165S | 11 | TB165L | 7 |
| 16 x 11 x 6 | TB166 | TB166S | 11 | TB166L | 7 |
| 16 x 11 x 7 | TB167 | TB167S | 11 | TB167L | 7 |
| 16 x 11 x 8 | TB168 | TB168S | 11 | TB168L | 7 |
| 24 x 11 x 2 1/2 | TB242 | TB242S | 17 | TB242L | 7 |
| 24 x 11 x 3 1/2 | TB243 | TB243S | 17 | TB243L | 7 |
| 24 x 11 x 4 1/4 | TB244 | TB244S | 17 | TB244L | 7 |
| 24 x 11 x 5 | TB245 | TB245S | 17 | TB245L | 7 |
| 24 x 11 x 6 | TB246 | TB246S | 17 | TB246L | 7 |
| 24 x 11 x 7 | TB247 | TB247S | 17 | TB247L | 7 |
| 24 x 11 x 8 | TB248 | TB248S | 17 | TB248L | 7 |
| 22 x 17 x 3 1/2 | TB223 | TB223S | 15 | TB223L | 11 |
| 22 x 17 x 4 1/4 | TB224 | TB224S | 15 | TB224L | 11 |
| 22 x 17 x 5 | TB225 | TB225S | 15 | TB225L | 11 |
| 22 x 17 x 6 | TB226 | TB226S | 15 | TB226L | 11 |
| 22 x 17 x 7 | TB227 | TB227S | 15 | TB227L | 11 |
| 22 x 17 x 8 | TB228 | TB228S | 15 | TB228L | 11 |
| 22 x 17 x 9 | TB229 | TB229S | 15 | TB229L | 11 |
| 22 x 17 x 10 | TB2210 | TB2210S | 15 | TB2210L | 11 |
| 22 x 17 x 11 | TB2211 | TB2211S | 15 | TB2211L | 11 |
| 22 x 17 x 12 | TB2212 | TB2212S | 15 | TB2212L | 11 |
| 22 x 17 x 13 | TB2213 | TB2213S | 15 | TB2213L | 11 |
| 22 x 17 x 14 | TB2214 | TB2214S | 15 | TB2214L | 11 |

COVERS

COVERS

| L" x W" | Model | L" x W" | Model |
|---------|---------|---------|---------|
| 11 x 8 | TB118C | 24 x 11 | TB2411C |
| 16 x 11 | TB1611C | 22 x 17 | TB2217C |

STACKING BOXES

STERILE WRAP RACKS

Sterile Wrap Rack - Low Profile Sterile wrap racks provide a safe, convenient place to hold wrap. Sizes up to 60" x 60". Rubber "O" rings reduce slipping of wraps. Ergonomically designed rack positions wrap at waist height for easy access. 5" polymer swivel casters, two with brakes, provide easy mobility and placement.

Model No. | **SWR1860C**

POLYMER CASTERS

Model No. | **CA55BP**



STERILE WRAP RACKS

Sterile wrap racks provide a safe, convenient place to hold wrap. One sheet, or several sheets, at a time can be removed quickly and neatly. The wire bottom shelf, standard on all units, can be used to hold extra wrap, or less frequently used sizes. The carrier assembly which supports the bars is adjustable in 1" increments along the height of the posts, so that it can be positioned at a comfortable level for users. The four bars can also be positioned in any of 18 slots along the carrier assembly. All models come with four 1" square bars as standard. Additional bars available. 5" polyurethane swivel casters provide easy maneuverability. Chrome finish.



ADDITIONAL SUPPORT BARS

Sold in Cartons of 4

| Size L" x W" x H" | Model No. | Model No. | Length" |
|----------------------|-----------------|---------------|---------|
| 24 x 48 x 68 | SWR2448C | SWRB48 | 48 |
| 24 x 60 x 68 | SWR2460C | SWRB60 | 60 |



Specialty Carts

CATHETER PROCEDURE CART



Catheter Procedure Cart holds all styles and sizes of catheter packages - on hooks, on shelves, or in tote boxes and bins. Catheter hooks are easily secured onto bars and can be adjusted to accommodate peel pouches. Catheters can be easily organized by dedicating a catheter hook or series of hooks to specific types of catheters. Clear plastic label holder attaches to end of hook to identify type of catheter by style, size or application. 5" polyurethane swivel casters, allow for easy maneuverability.

| Size L" x W" x H" | Model No. | Number Of Catheter Hooks |
|----------------------|-----------------|-----------------------------|
| 24 x 48 x 60 | CPC2448C | 32 |
| 24 x 60 x 60 | CPC2460C | 40 |

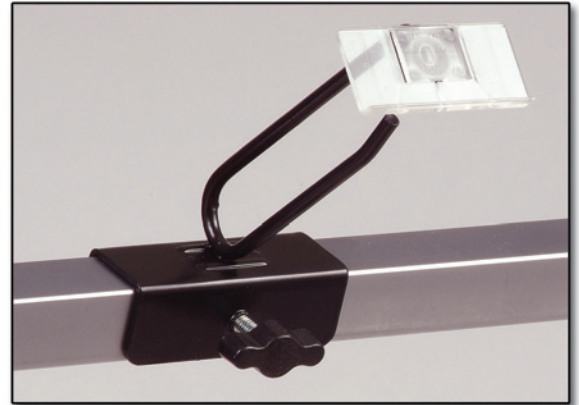

CATHETER HOOKS WITH LABEL HOLDER

Model No.
CPCH4



CATHETER SIDE BAR

Model No.
CSB24C

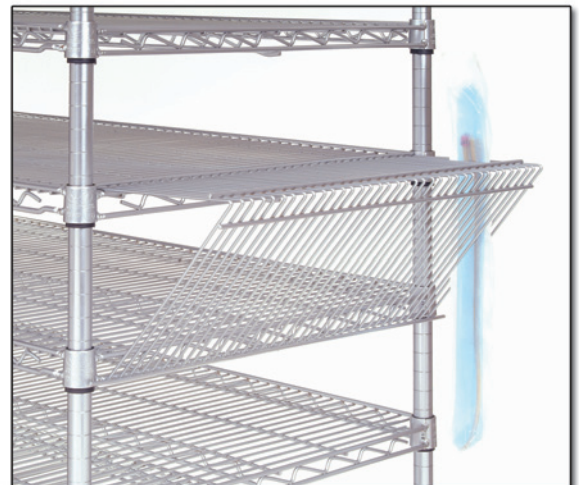

FOGARTY CATHETER BASKET

Model No.
FCB24C

CATHETER CART WITH BASKET

Catheter Cart & Baskets open wire design provides greater visibility to help find cartons faster, check inventory more efficiently and eliminate opening cartons unnecessarily. Standard Unit consists of nine shelves, 77 catheter baskets and 77 plastic bin markers for basket identification. Polyurethane swivel casters provide easy mobility. Chrome finish.

| | |
|--------------|---------------|
| Size | Model No. |
| L" x W" x H" | |
| 24 x 48 x 68 | CCB77C |

EXTRA BASKETS

| |
|--------------|
| Model No. |
| CB24C |

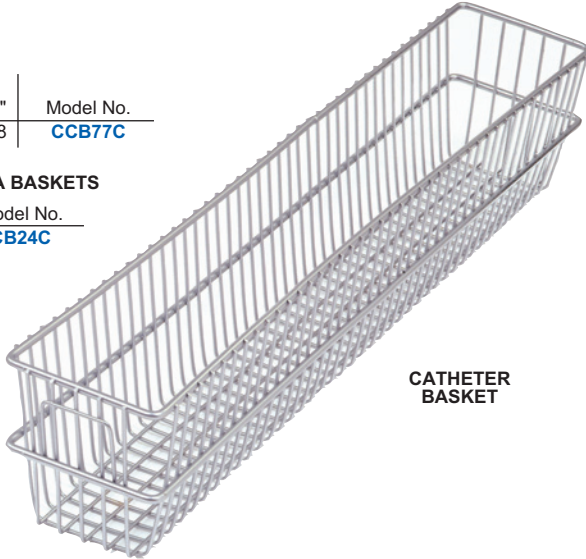

CATHETER BASKET



CATHETER CART WITH BASKET

SLANT SHELF SUTURE CART

Nexel Slant Shelf Suture Carts allow maximum visibility and accessibility. Product restocking is fast and easy. Rear load/front pick assures first in, first out product rotation. Angled shelves allow gravity feed. 400 lb. Capacity shelves adjust on one-inch increments. 5" Polyurethane casters offer mobility. Optional Dividers keep products from falling off shelf and provide lanes for products. Chrome finish.

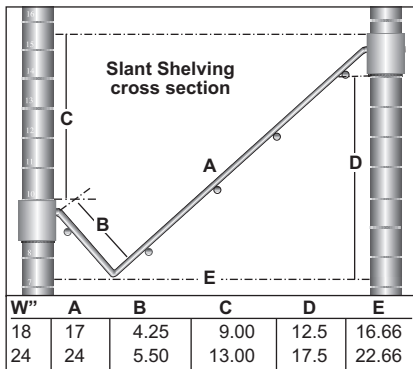

SLANT SHELVES

| | |
|---------|----------------|
| Size" | Model No. |
| 18 x 36 | SS1836C |
| 18 x 48 | SS1848C |
| 24 x 36 | SS2436C |
| 24 x 48 | SS2448C |

DIVIDERS

| | |
|-------|-------------|
| Size" | Model No. |
| 18 | SS18 |
| 24 | SS24 |

POST

| | |
|-------|-------------|
| Size" | Model No. |
| 54 | P54C |
| 63 | P63C |
| 74 | P74C |



SHOWN WITH OPTIONAL DIVIDERS

CARTS - CONSIST OF 4 SLANT SHELVES, 4 POSTS, 1 STANDARD SHELF AND 1 THREE SIDED FRAME

| 54" HIGH | | 63" HIGH | | CASTERS | |
|----------|-----------------|----------|-----------------|-----------------|--------------|
| Size" | Model No. | Size" | Model No. | Type | Model No. |
| 18 x 36 | 18365SSC | 18 x 36 | 18366SSC | 5" Polyurethane | CA5SB |
| 18 x 48 | 18485SSC | 18 x 48 | 18486SSC | 2 with brake | |
| 24 x 36 | 24365SSC | 24 x 36 | 24366SSC | 5" Rubber | CA5BR |
| 24 x 48 | 24485SSC | 24 x 48 | 24486SSC | 2 with brake | |



11 Harbor Park Drive
Port Washington, NY 11050
U.S.A.

1-800-245-6682

NY: 1-516-484-5225

FAX: 1-516-625-0084

E-mail: nexelinfo@nexelwire.com

www.nexelwire.com

DISTRIBUTED BY

N0109